

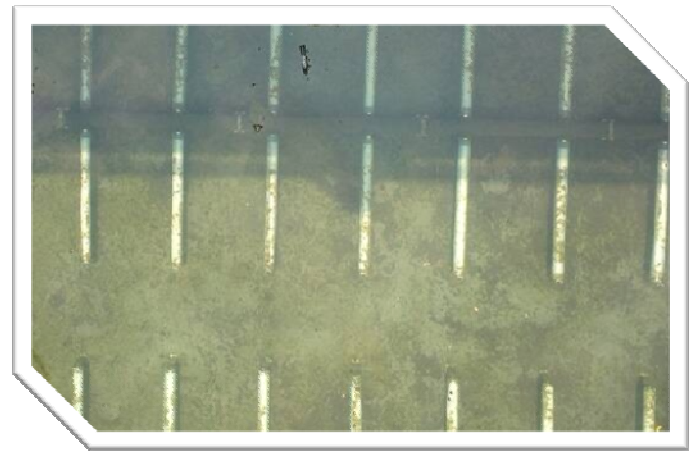

FINE BUBBLE TUBE DIFFUSER

SAN LEE Industry Co., Ltd.

- Fine pore flexible membrane diffusers provide operational flexibility with maximum oxygen transfer efficiency for aeration tank.
- KamAir diffusers employ a 3/4 inch diameter PT (female) threaded connection for ease of installation/maintenance and universal application.
- Alternate materials of constructions are available for special applications.



PRODUCT DATA SHEET

TYPE	Available Membrane Material	Diameter x Length(mm)	Air Flow (m ³ /h)	Active Surface Area (m ²)	Pore Number
KAL300	EPDM Silicone	65x300	2.0-10.0	0.05	8,640
KAL600		65x600	3.0-14.0	0.09	19,584
KAL1000		65x1000	5.0-24.0	0.16	34,624

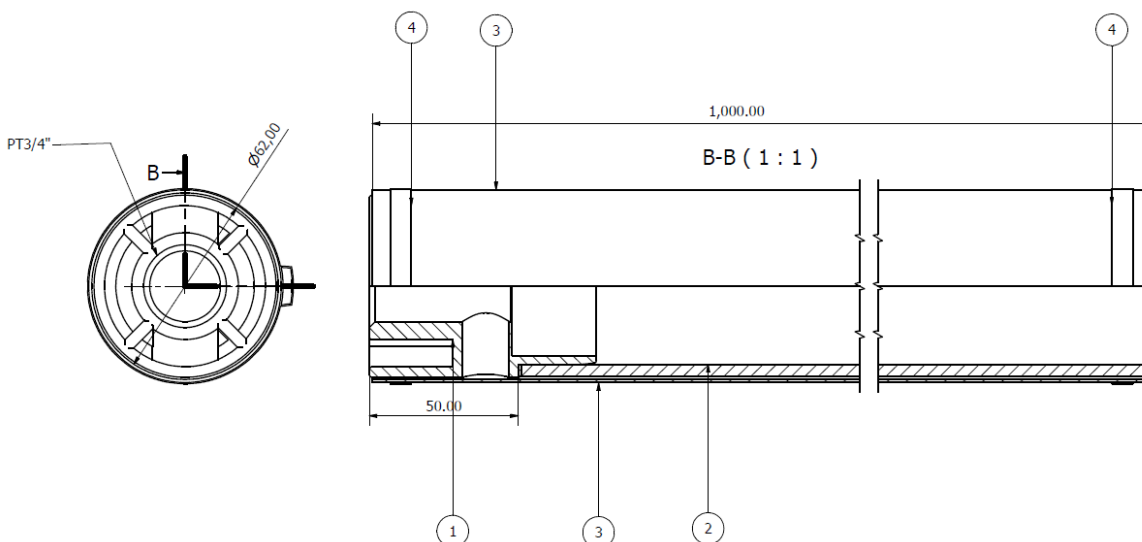

1. ADAPTER
2. SUPORT TUBE
3. MEMBRANE
4. CLAMP BAND